

ESCPEC Inc.
Air-Foil Aluminum Control Damper

Series: 100

Model: FB (blades in Face and Bypass action)

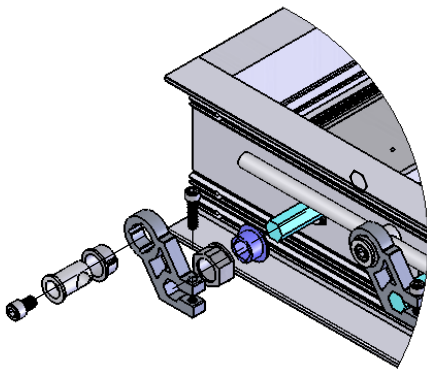
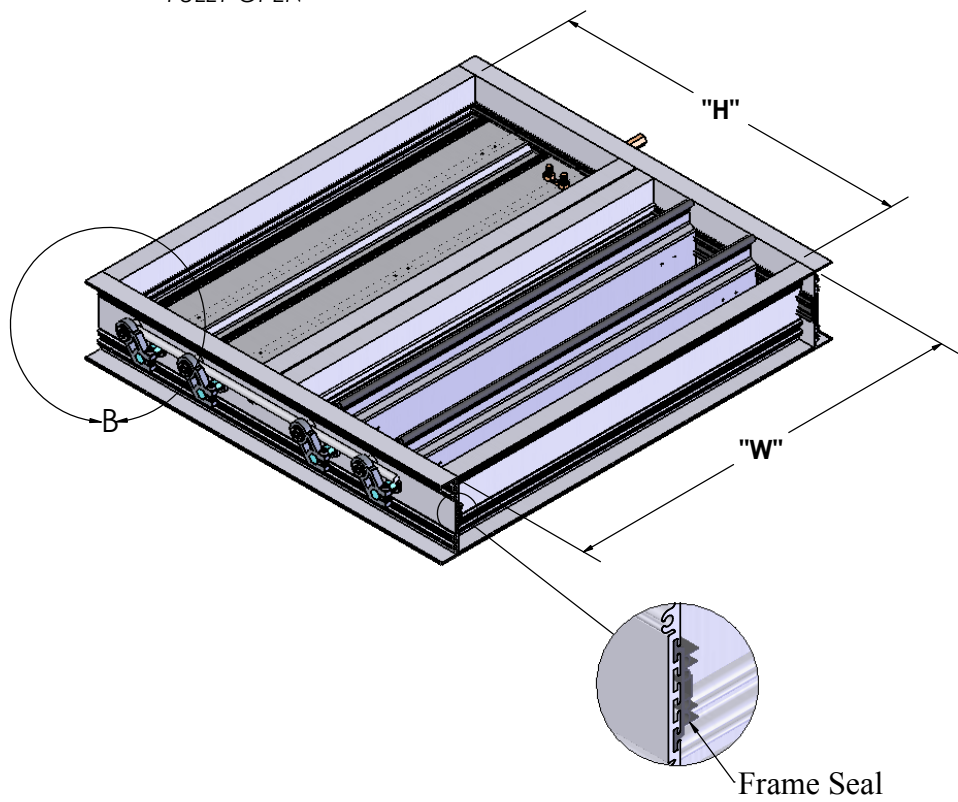
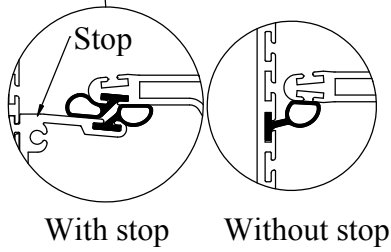
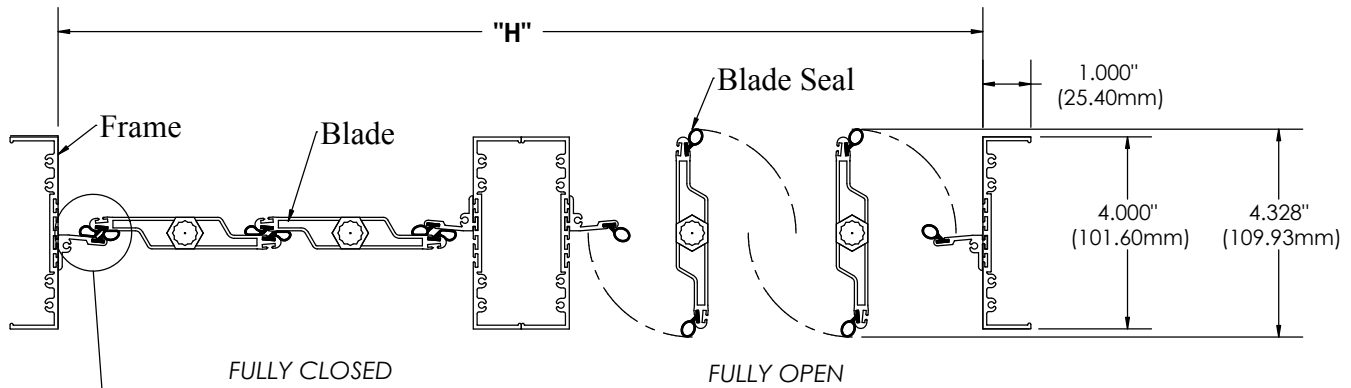

DETAIL B
Linkages/Crankarm/Bearings

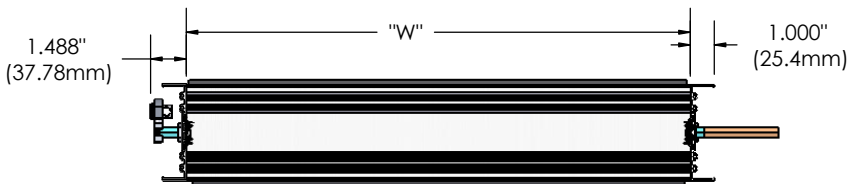

Overall dimensions

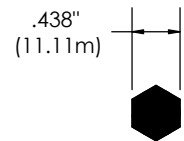

Drive Shaft

ESCPEC Inc.

Air-Foil Aluminum Control Damper

STANDARD CONSTRUCTION:

- **Frame:**
Aluminum extrusion 6063-T5 with a minimum 0.80" (2.03mm) in thickness, 4" deep and 1" mounting flange.
 - **Blade:**
Aluminum extrusion 6063-T5 in air-foil profile with a minimum 0.063" (1.60mm) in thickness and 4" wide.
 - **Seals:**
Blade seal is TPV rubber with a bulb profile. Frame seal is silicone rubber with dual bulbs and four walls profile.
 - **Bearings:**
Moulded Acetal (POM) copolymer that has high tensile strength, fatigue resistance, excellent lubricity and moisture absorption.
 - **Blade Stop:**
Aluminum extrusion 6063-T5. Most dampers have stops installed at two end frames except for some dimension limitation or customer's request.
 - **Axles:**
Hexagonal aluminum rod, 7/16" (11.11mm) flat to flat.
 - **Drive shaft:**
Hexagonal steel rod, 7/16" (11.11mm) flat to flat and 12" in length.
 - **Linkage hardware:**
Concealed in frame and constructed of aluminum and steel.
 - **Finish:**
All aluminum parts have mill finish. All steel parts are zinc plated.
 - **Operationg Temperature:**
From -40 °F (-40 °C) to 180 °F (80 °C).
 - **Air Leakage:**
Does not exceed 3 cfm/ft² against 1" w.g. and 6 cfm/ft² against 4" w.g.
 - **Damper Sizes:**
Minimum 4 1/4"Wx4 1/4"H (108mm x 108mm), Maximum 60"Wx60"H (1524mm x 1524mm).
-

OPTIONS:

- **Finish:** Salt water resistance.
Clear Anodize for all aluminum parts. All steel parts are stainless steel.
 - **Filter channel package:**
1" or 2" filter channels are directly mounted to damper frame.
 - **Wire mesh and screen package:**
1/2"x0.05 wire mesh and screen are attached to damper (outdoor air / exhaust air) to prevent bugs or insects to enter in.
-